

# Cone splitters

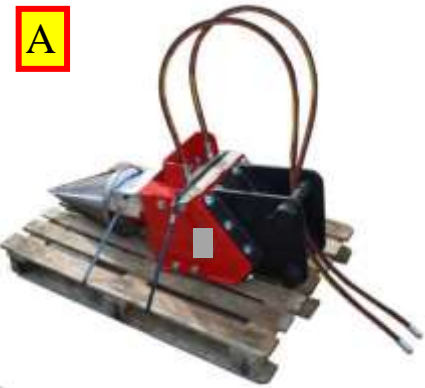

| Model            | Weight Kg | Machine Dimensions cm H X W X D | Log length | Max Log diameter | Recommended machine weight | Oil Flow | Oil Pressure |
|------------------|-----------|---------------------------------|------------|------------------|----------------------------|----------|--------------|
| M1 – 4.0/4.7Roli | 90        | 85 x 32 x 36                    | 1-2 meters | 70 cm            | 1000 -3500 kg              | 15/50L   | 200 -230 bar |
| M1 – 10Roli      | 130       | 88 x 25 x 25                    | 1-2 meters | 90 cm            | 2500 -8000 kg              | 30/80L   | 170 -200 bar |
| M1 – 4.0/4.7K    | 135       | 110 x 36 x 45                   | 1-2 meters | 90 cm            | 2500 -7000 kg              | 30/80L   | 170 -230 bar |
| M2 – 4.0/4.7 M   | 170       | 110 x 36 x 45                   | 1-4 meters | 90 cm            | 3000 – 7000 kg             | 50/80L   | 170-230 bar  |
| M2 – 4.0/4.7 KS  | 220       | 136 x 47 x 56                   | 1-4 meters | 100 cm           | 4000-10000 Kg              | 50/80L   | 170-230 bar  |
| M2 – 4.0/4.7S    | 290       | 136 x 47 x 56                   | 1-4 meters | 110 cm           | 5000-15000 Kg              | 65/130L  | 170-230 bar  |
| M3 – 4.0/4.7S    | 400       | 136 x 47 x 56                   | 1-5 meters | 150 cm           | 7000-20000 Kg              | 90/170L  | 170-230 bar  |
| M5 – 4.0/4.7S    | 600       | 240 X 92 X 92                   | 1-7 meters | 200 cm           | 10000-25000Kg              | 120/250L | 230-270 bar  |

To fit onto 360 excavators, Back-hoes, Skid Steers, Loading Shovels, Tractor loaders, Cranes, Forwarding trailers and many other applications. Retail price includes mounting bracket, pins and hoses with blank ends as per picture 'A' above.

**M1 – 4 Roli From: £ 2,400 + Vat.      M1 – 10 Roli From: £ 3,980 + Vat.**  
**M1 – 4 K From: £ 5,930 + Vat.      M2 – 4 K/M From: £ 8,700 + Vat**  
**M2 – 4 KS From: £ 9,845 + Vat.      M2 – 4 S From: £ 10,460 + Vat.**  
**M3 – 4 S From: £11,720 + Vat.      M5 – 4 S From: £18,980 + Vat.**

**Hardened Cone for M2 and M3S models From; £1,000**  
**60,70,80,100,120,152,229,305,457mm augers From: £965-1,495.**

# Cone splitter Fitting

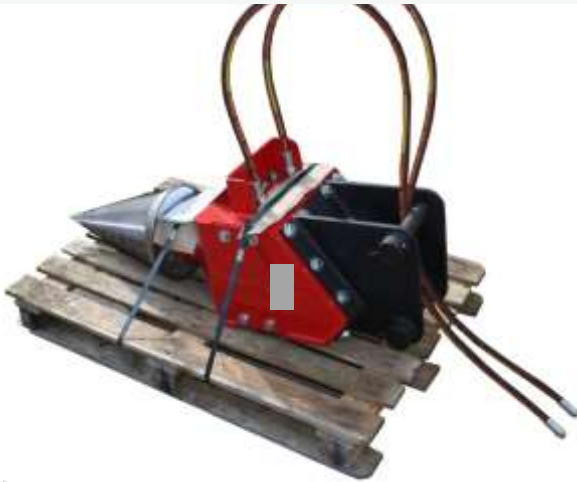

**Machines must be fitted with DOUBLE ACTING service to the boom end.**

Some machines have hammer lines and valve but they may only be single acting. Please check.

**HOSE DIAMETER (Supplied):**  
 Roli/M1/M2 = 1/2 inch BSP  
 M3 = 3/4 inch BSP

**HOSE LENGTH (Supplied):**  
 Roli/M1/M2 = 1.8 Metres  
 M3 = 2.2 Metres

This is how it will be supplied if purchased at full retail price. Bolted on boom bracket with two pins and two hoses.



**Hose ends supplied:**  
 Roli/M1/M2 = 1/2 inch BSP Male  
 M3 = 3/4 inch BSP Male

To attach your cone splitter to your machines hydraulic circuit you required the correct fittings on the end of the hoses the splitter is fitted with. These can normally be be sourced from a local Ag dealer or hydraulics supplier. If you wish we can supply these but we need to know what is fitted to your machine.

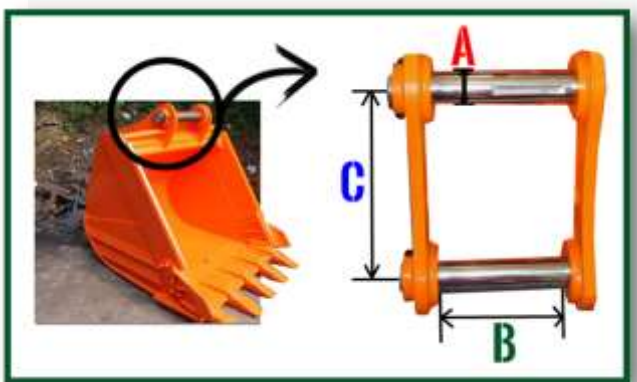

## DIMENSIONS REQUIRED

- A Pin Diameter = \_\_\_\_\_ mm
- B Pin Length between Jaws = \_\_\_\_\_ mm
- C Distance between pin CENTRES = \_\_\_\_\_ mm
- D Distance from hyd couplings to boom end = \_\_\_\_\_ mm

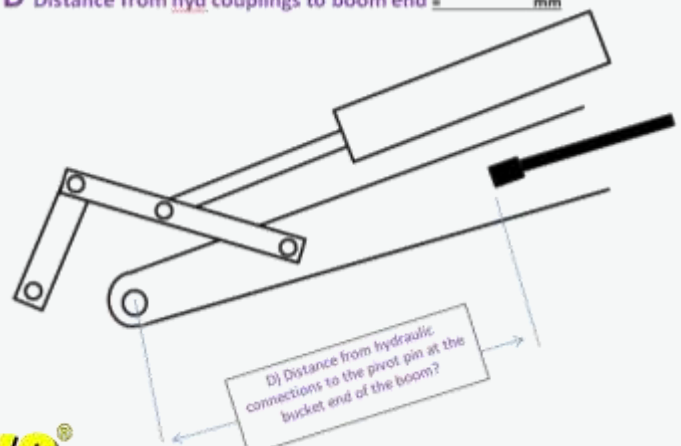

## RIKO UK / ALPINE TRACTORS

Depots North and South  
 www.alpinetractors.com  
 Tel: +44 (0)1420 487300  
 Fax: +44 (0)1420 479547  
 Email: sales@riko-uk.com



**RIKO UK / ALPINE TRACTORS**

Depots North and South

[www.alpinetractors.com](http://www.alpinetractors.com)

Tel: +44 (0)1420 487300

Fax: +44 (0)1420 479547

Email: [sales@riko-uk.com](mailto:sales@riko-uk.com)